

FSD-TD Series

Fire and Smoke Dampers



BSB are pleased to introduce with effect from January 4th 2010 the FSD Series Fire and Smoke Damper will be superseded by the NEW FSD-TD Fire and Smoke Damper as described on this leaflet.

The NEW FSD-TD damper has been extensively tested gaining certification and approvals to ensure that it complies with the current Fire Regulations and Building Regulations applicable to Fire Damper installation.

The FSD-TD damper will be offered and included in all newly prepared quotations and any orders received will be processed as the new damper model.

Any quotations prepared prior to the end of December 2009 that included the FSD Series model, and where orders are received referring to these quotations, our NEW FSD-TD Series model will be processed for manufacture unless specifically requested otherwise.

Please check all prepared quotations and acknowledged orders carefully to ensure that equipment detailed fully meets your project specification.

- LPCB certificated fire dampers (LPS 1162)
- ES classified fire dampers with reduced smoke leakage characteristics (BS EN 13501-3)
- Tested installation methods in differing supporting constructions (BS EN 1366-2)
- Able to respond to smoke alarms for the protection of escape routes and areas with sleeping risk (ADB)
- Able to be controlled by smoke and fire control systems (BSB damper control panels)
- Tested and assessed installation methods in differing supporting constructions (BS 476-20/22)

FSD-TD Series

Fire and Smoke Dampers



Model FSD-TD - S

Square/Rectangular Spigot Connection

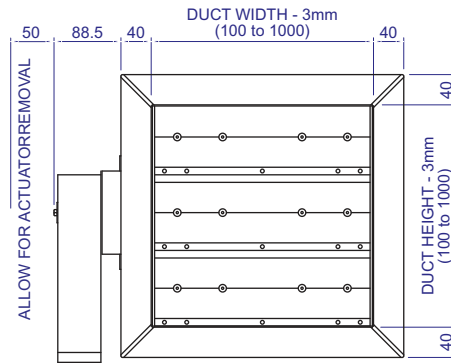
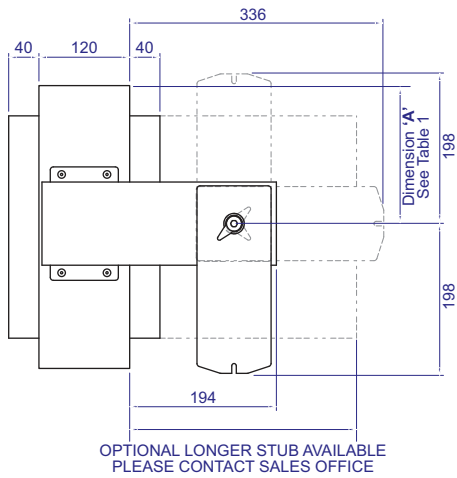

Model FSD-TD - C

Circular Spigot Connection

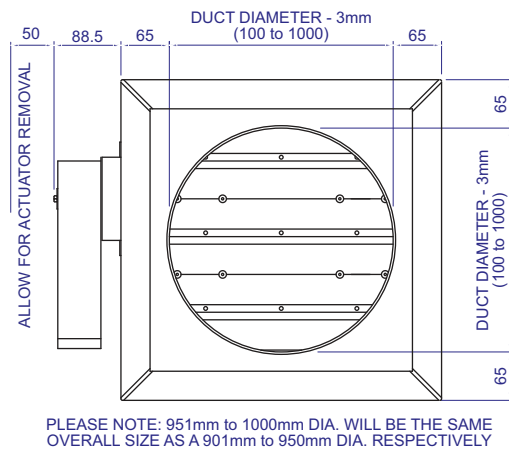
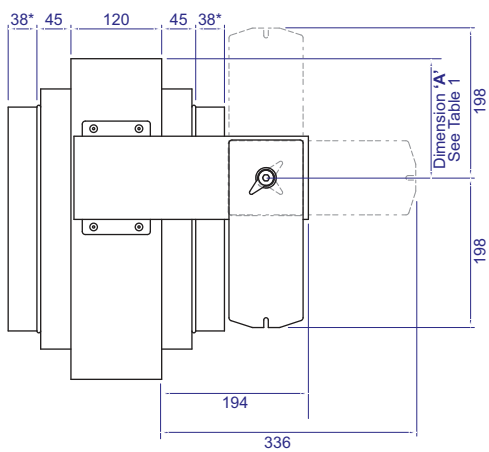

Model FSD-TD - O

Flat Oval Spigot Connection

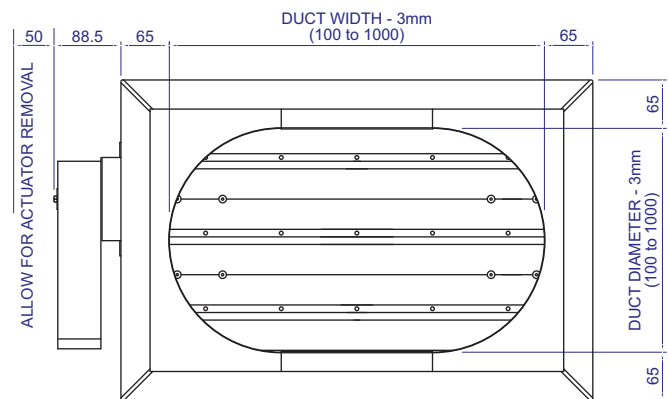
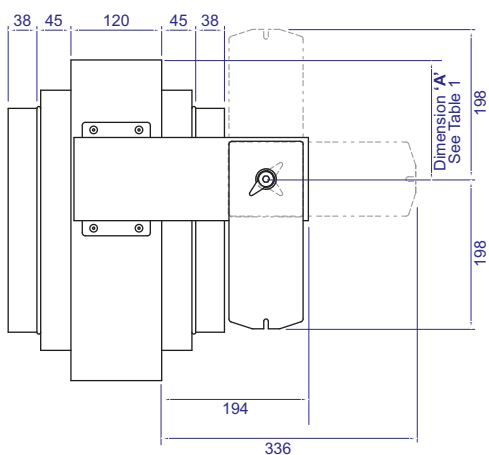

BSB Engineering Services Limited

Unit E, Tribune Drive, Trinity Trading Estate, Sittingbourne, Kent ME10 2PD

Tel: +44 (0)1795 422609 • Fax: +44 (0)1795 429543

Email: sales@bsb-dampers.co.uk • Website: www.bsb-dampers.co.uk

BSB Engineering Services Ltd. reserves the right to modify or withdraw any specification without prior notice that may result from continuous product development. The information contained within this brochure is correct at the time of going to press.

A member of the Maico group

